

Miter box plan

Miter boxes are useful in cutting angles of 45 degrees. It can be easily adjusted to cut different depths, and the angle can be changed from 45 to 135 degrees. Wooden miter boxes are often made by the woodworker himself.

Wooden miter box is composed of three pieces – a bottom and two sides. It is necessary that the bottom piece be uniform in width and thickness, and have joined edges, and it is well to prepare the other pieces in the same way.

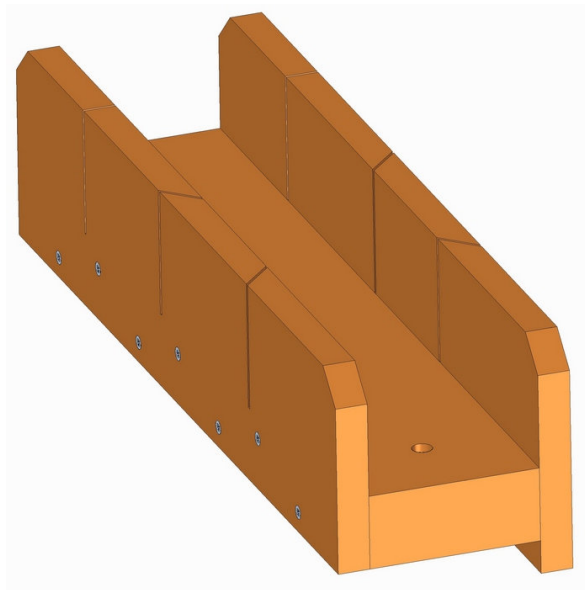

The kerf for the saw to run in should be made with a back saw or a panel saw. For cutting the kerf you should use the same saw that you will normally use for mitreing.

If possible use hard fine grained wood, such as straight grained birch, cherry, oak or beech. Although soft wood is easier to work with and will serve your purpose, yet a far more accurate and enduring miter box may be constructed from hardwood. Do not use spruce or any wood liable to warp and twist.

The least inaccuracy in making the miter box will result in a finished box which is worthless and worse than not at all.

Testing after assemblage:

Place a straight piece of wood in the box with one edge resting against one of the sides on the bottom and placing your saw in the 45 degrees kerf, saw through the piece of wood while holding it firmly in position with your thumb pressing it against the inside of the box. Do the same way with another piece and then lay the pieces on a flat surface with the two bevelled, or diagonal, ends together and with your try square test them to see if their edges come true with the square. If everything has been done carefully you will find that the pieces form a perfect square (right angle corner).

The measurements are given in millimeters, while the measurements given in inches are in brackets (1 inch = 25, 4 mm).

Wooden miter (mitre) box plan – Assembly 2D drawing

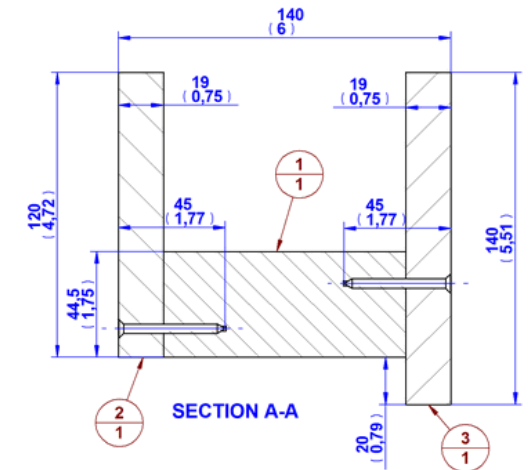
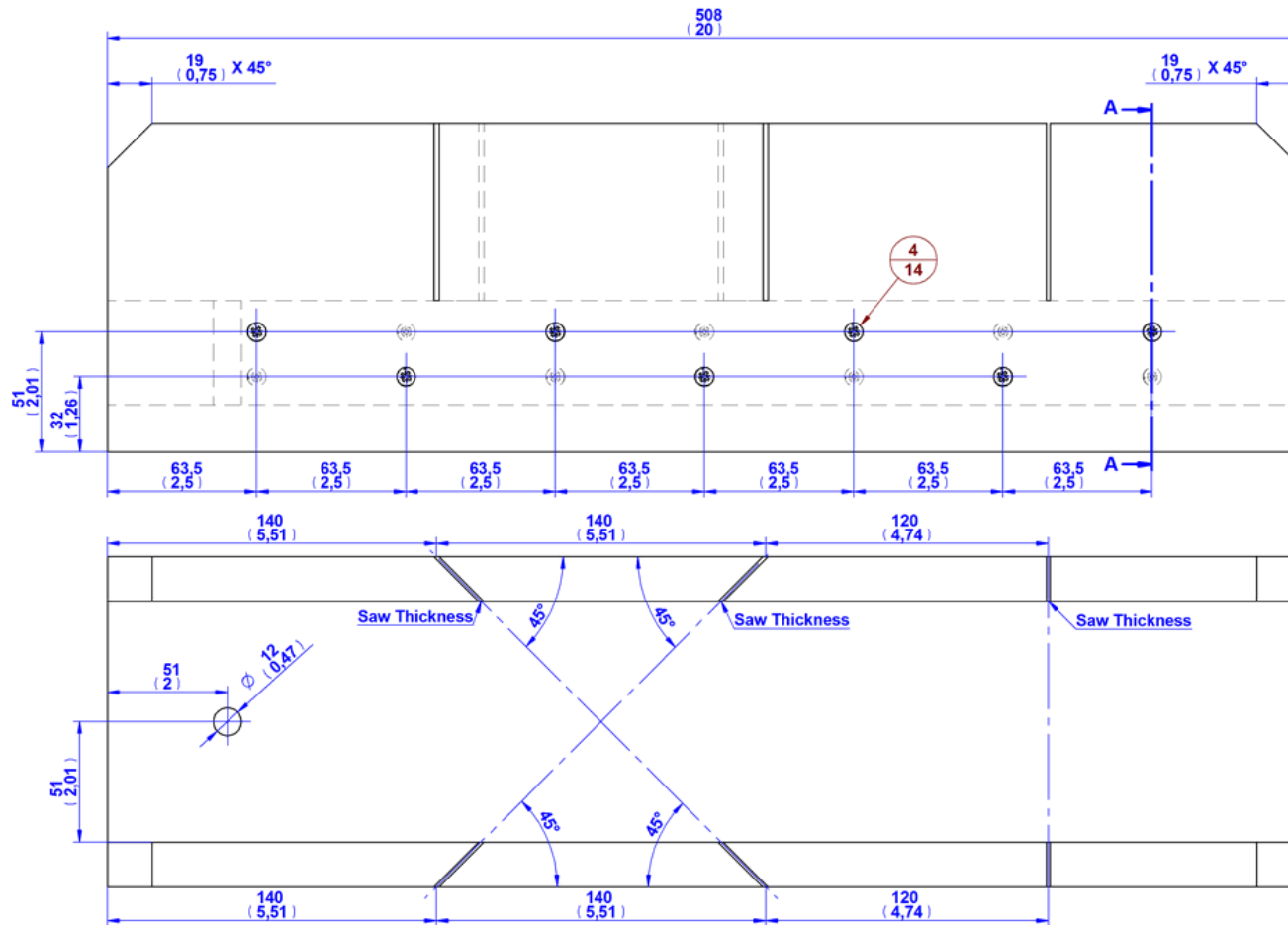

Item Number	Title	Quantity	Material
1	Bottom	1	hardwood
2	Side 2	1	hardwood
3	Side 1	1	hardwood
4	Wood screw D4 x 45mm	14	Steel

