

## Sliding four spice box plan

This functional and decorative spice box is just perfect kitchen item for the persons, who love to cook on a daily basis, while it can hold some other spices in boxes like curry and basil, cinnamon and not just salt and pepper. And additional fifth box can be used to hold chili peppers for that Mexican dishes. Or you can keep toothpicks there.

Sliding four spice box is easy to make, and fun to use. Its wide openings allow you to grab spices with big spoon, or hand, by simply sliding the lids from the box tops. By changing its dimensions, you can easily adjust this sliding box for a different purpose.

Wash it with warm water by hands

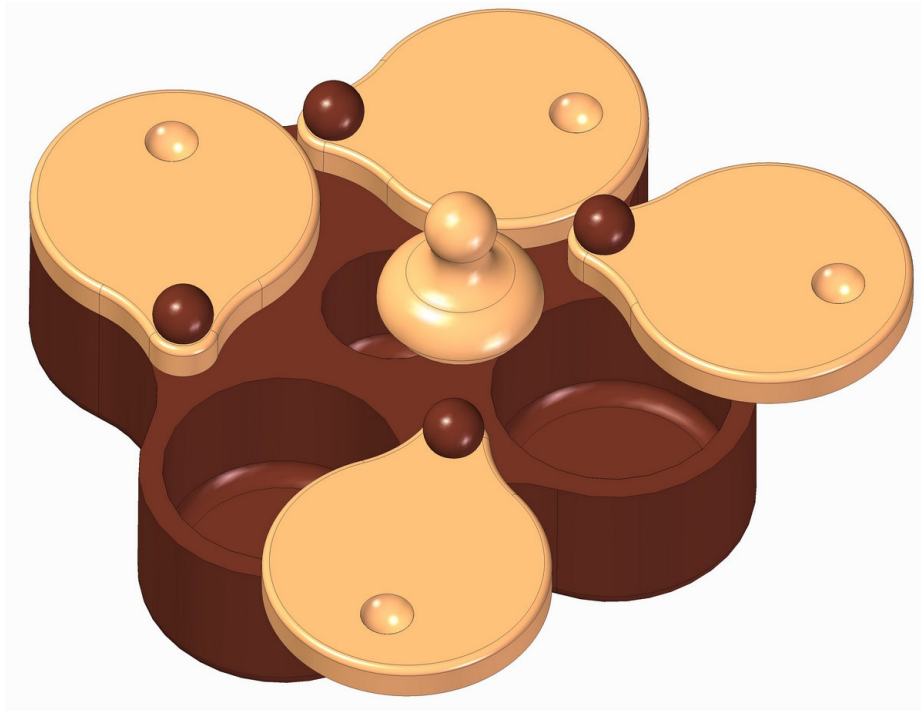

The measurements are given in millimeters, while the measurements given in inches are in brackets (1 inch = 25, 4 mm).

Sliding four spice box plan – Parts list

Item Number	Title	Quantity	Material
1	Bowl	1	Wood
2	Cover	4	Wood
3	Axle	4	Wood
4	Central cover	1	Wood

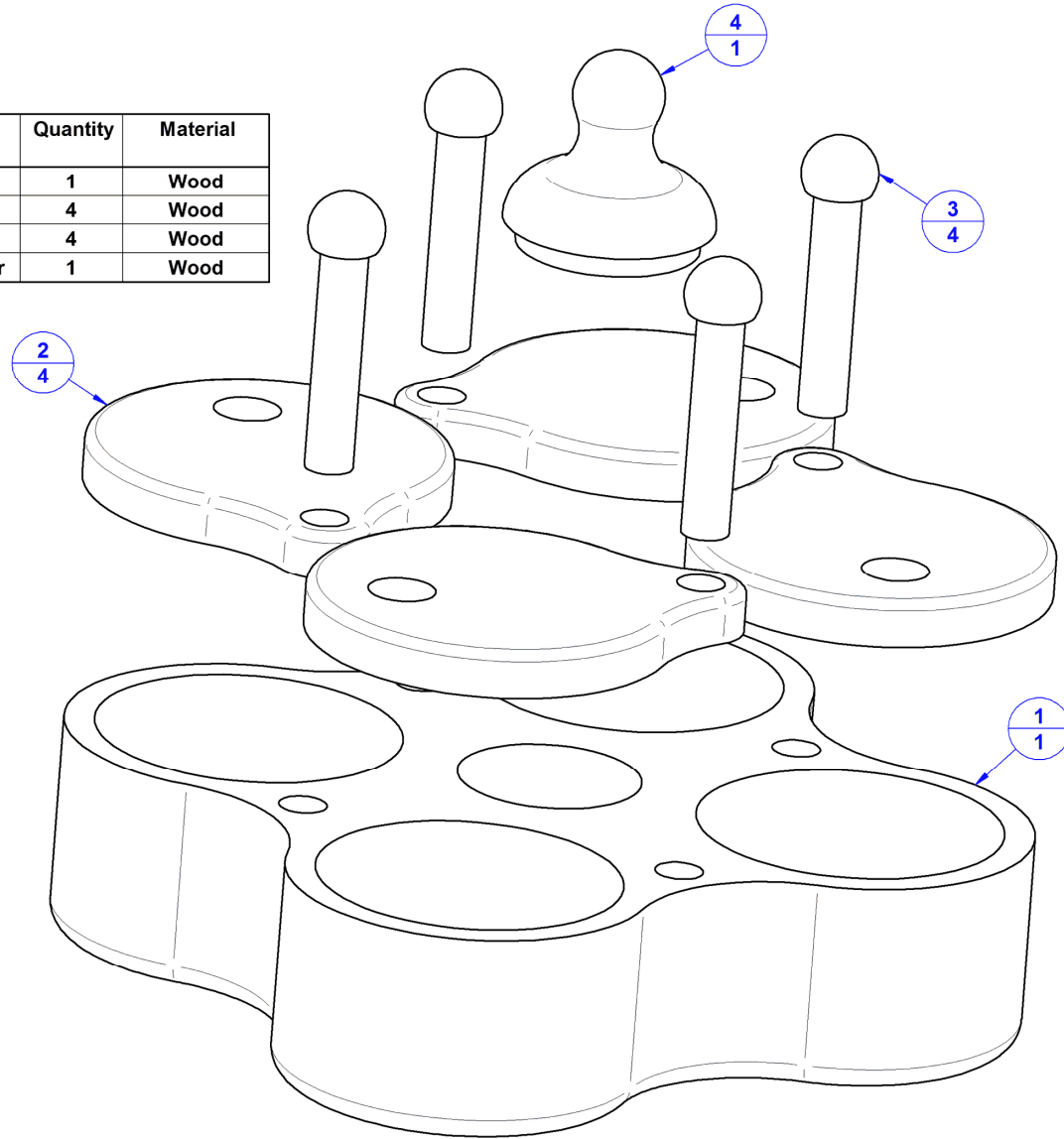

Sliding four spice box plan – Assembly 2D drawing

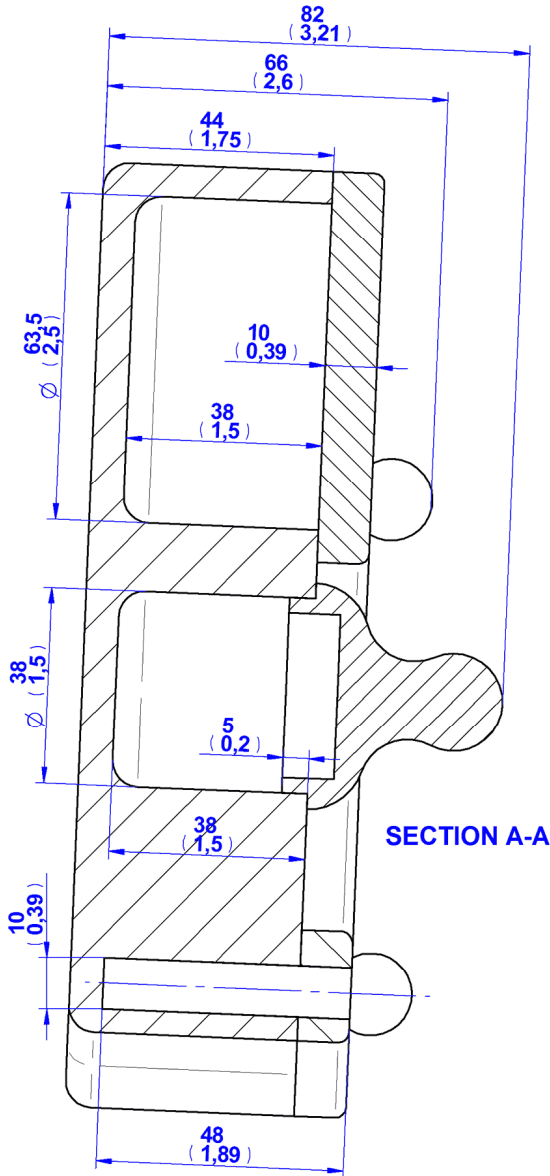
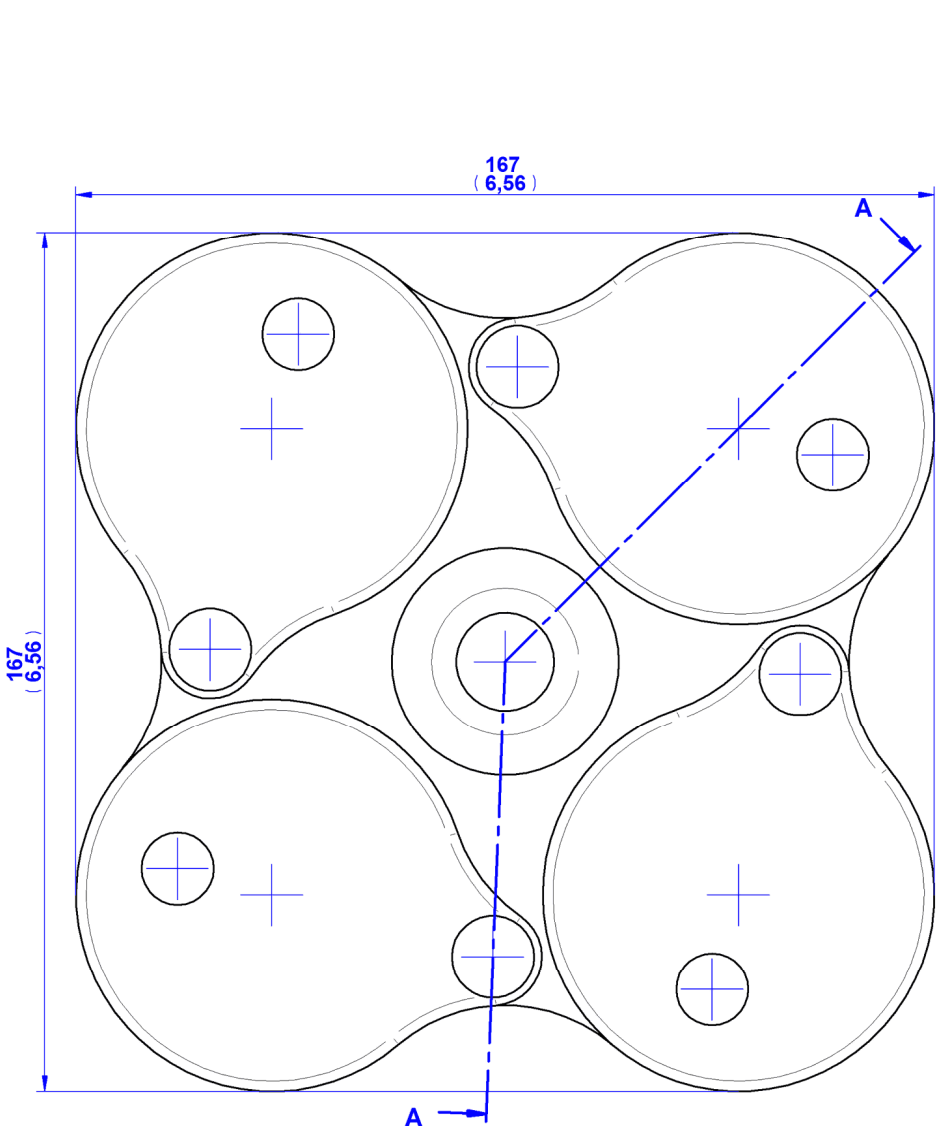



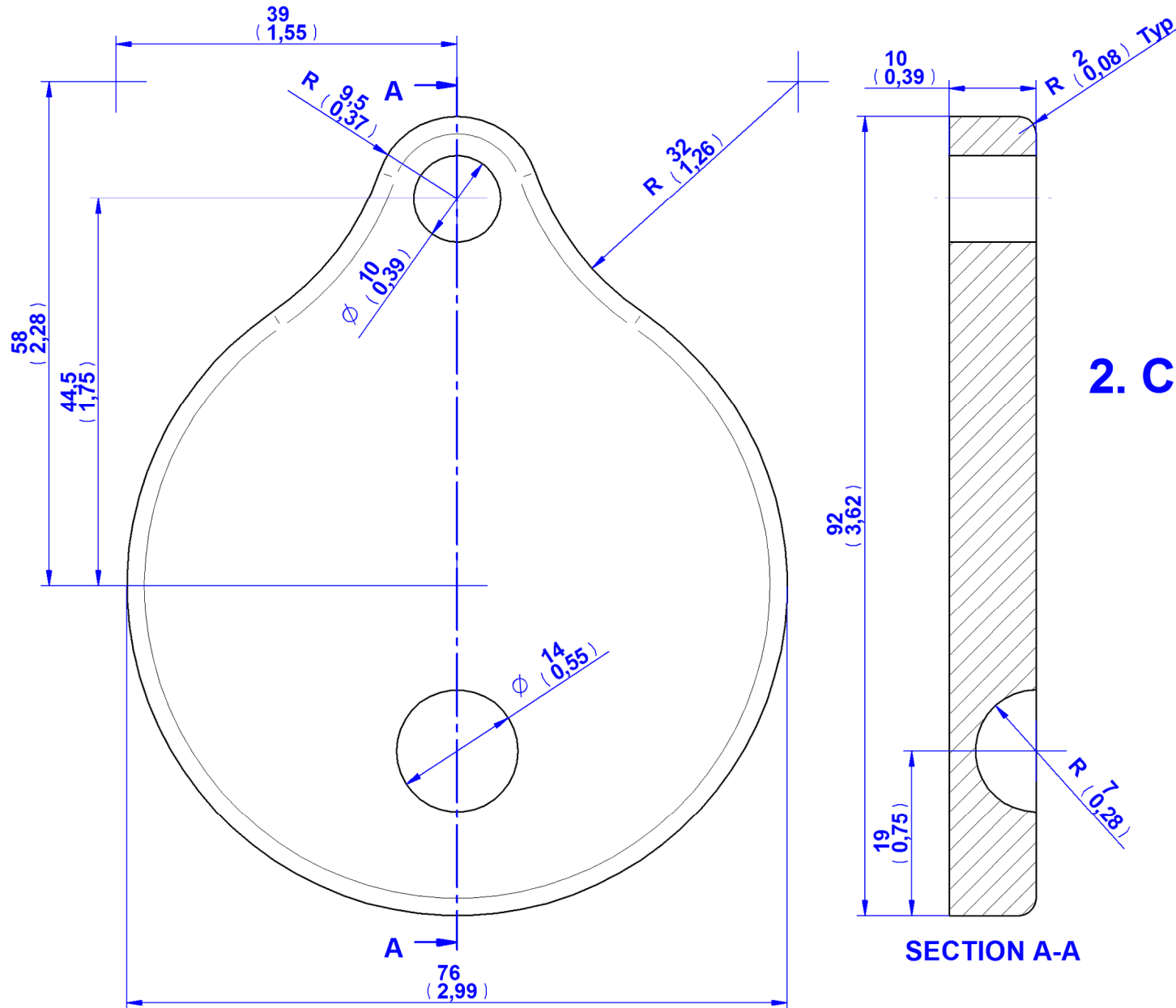

## 2. Cover

SECTION A-A

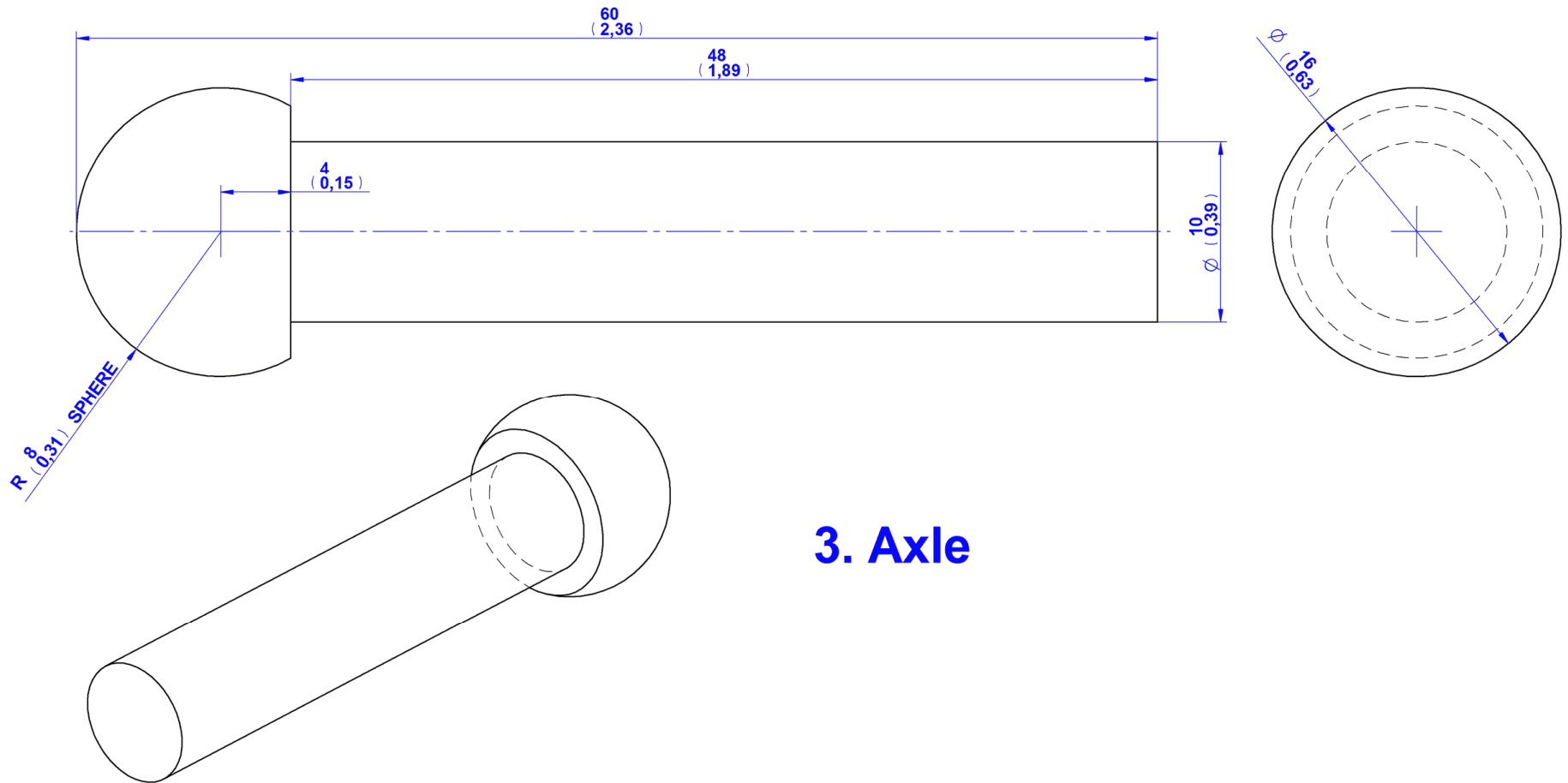

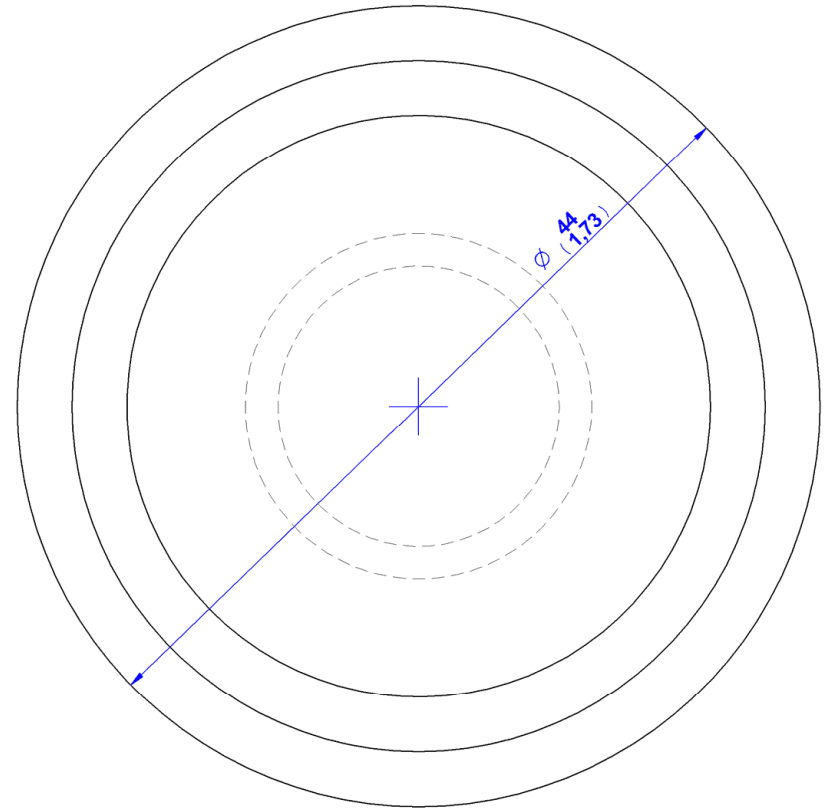
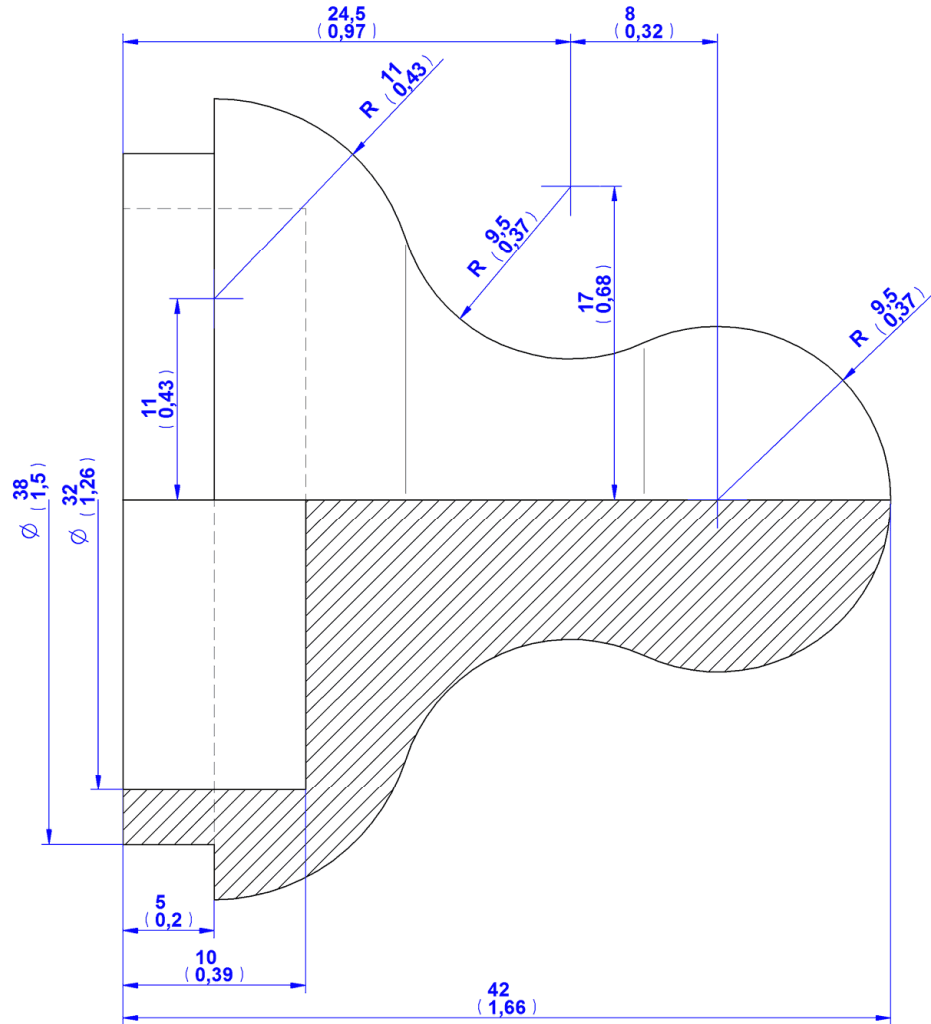

#### 4. Central cover

## Assemblage instructions

Attach the Covers (part 2) and Axles (part 3) to the Bowl (Part 1) using glue.

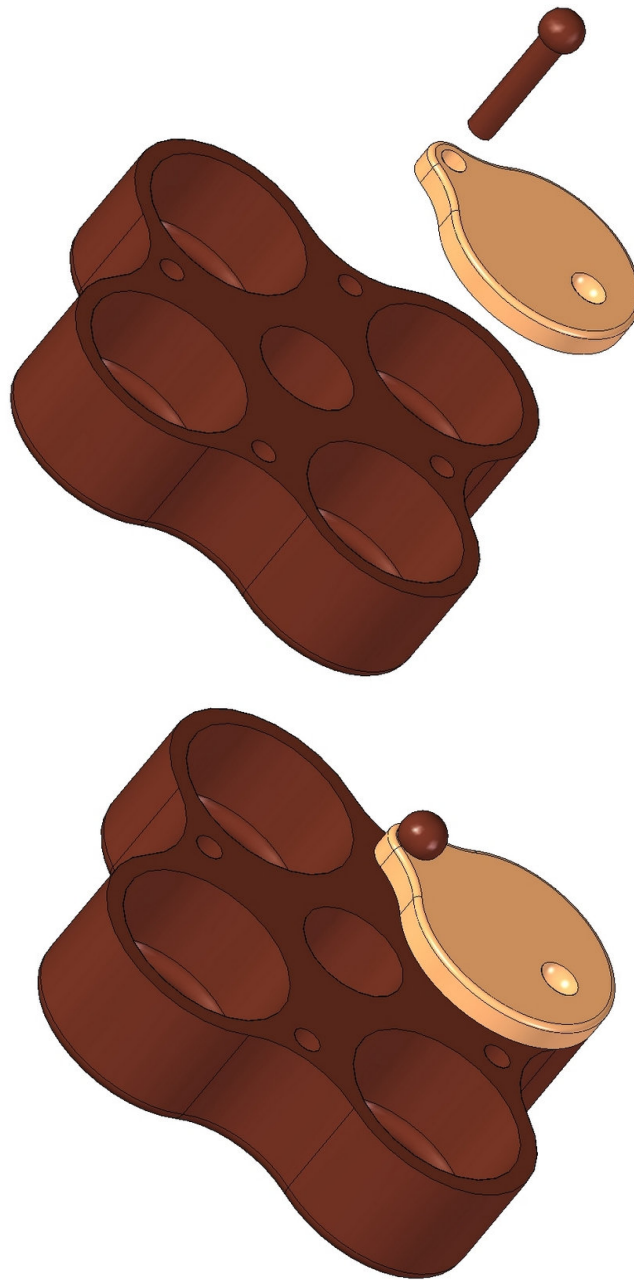



If you wish to keep some kind of spice in the central hole on the Bowl (part 1), then you need the Central cover (part 4), but If you intended to keep toothpicks in it (and you have to admit, that it is ideal place to keep toothpicks), you do not have to make this Cover.

