

## Wooden handle massager plan

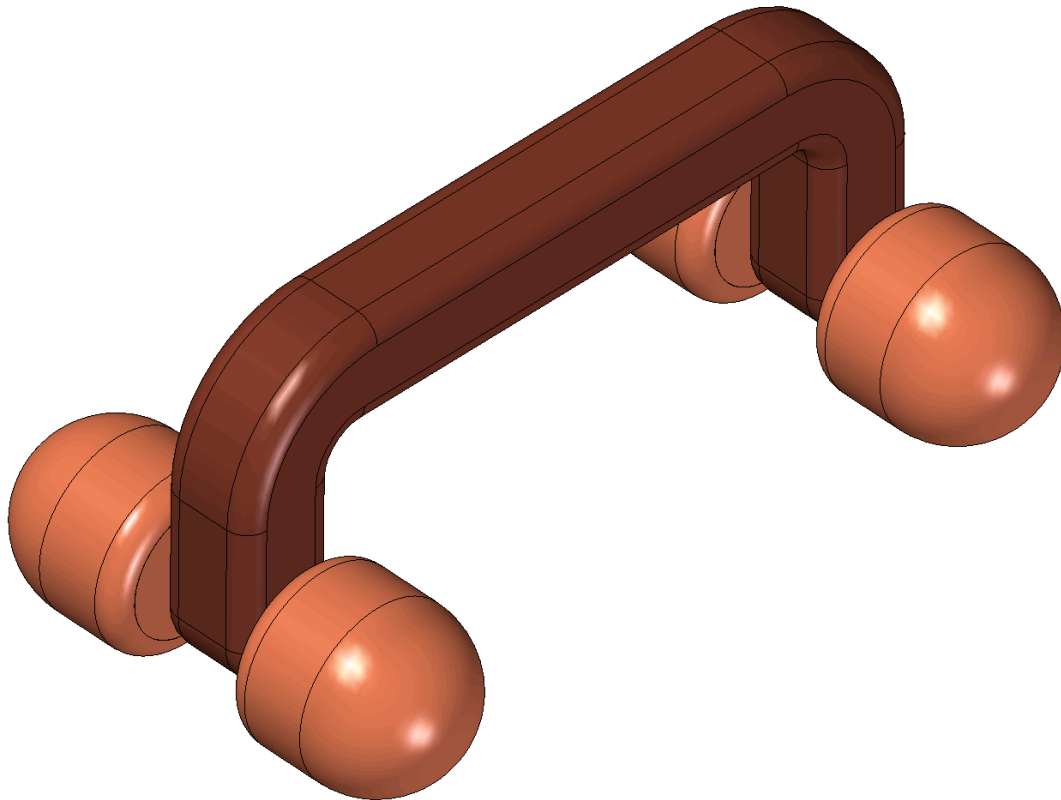

**Handle massager parts list**

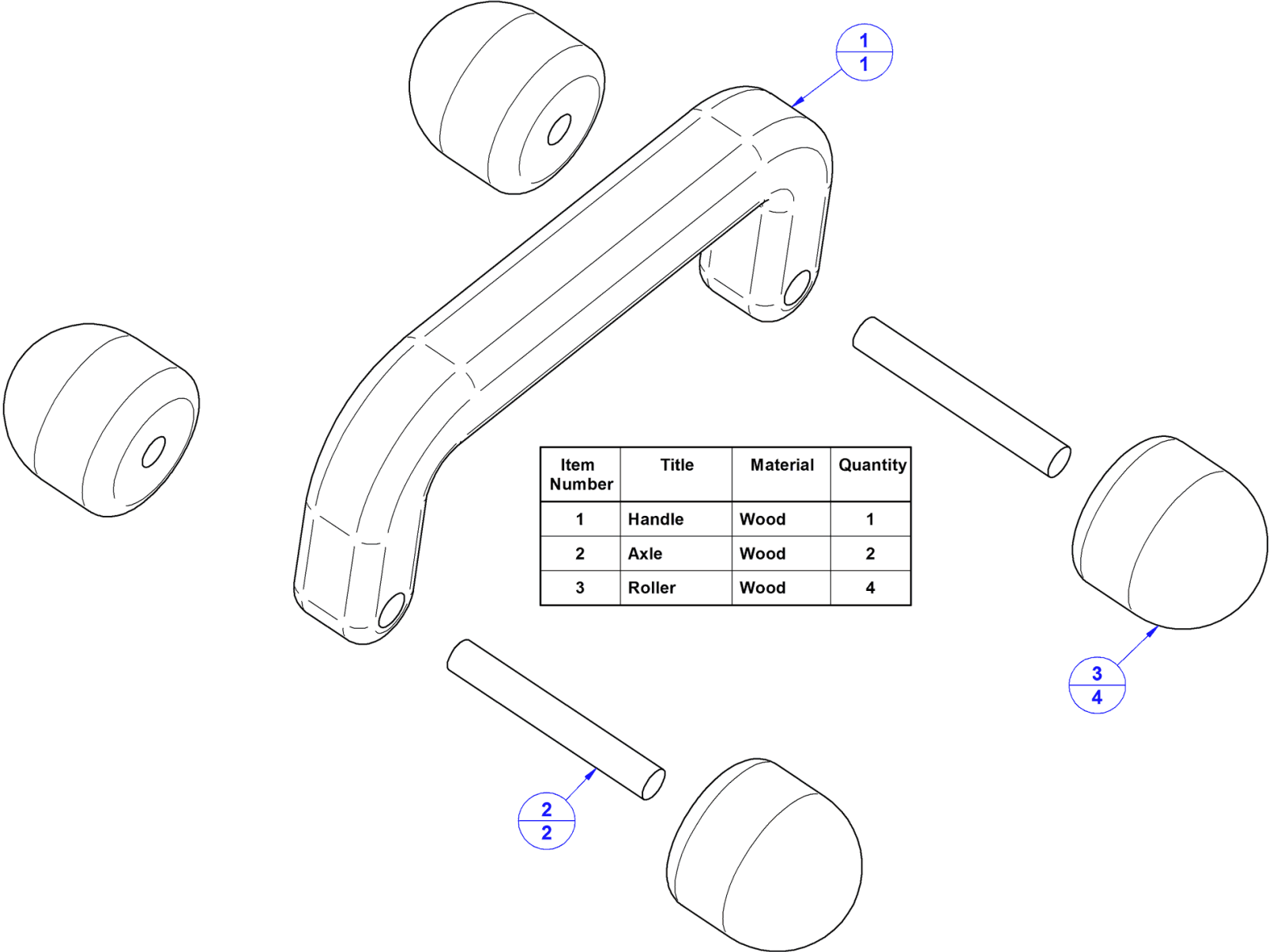

Item Number	Title	Material	Quantity
1	Handle	Wood	1
2	Axle	Wood	2
3	Roller	Wood	4

Handle massager assembly 2d drawing

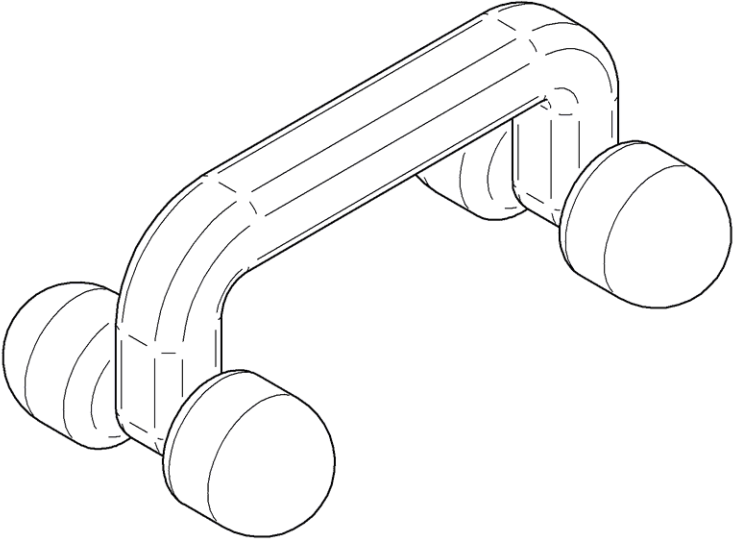
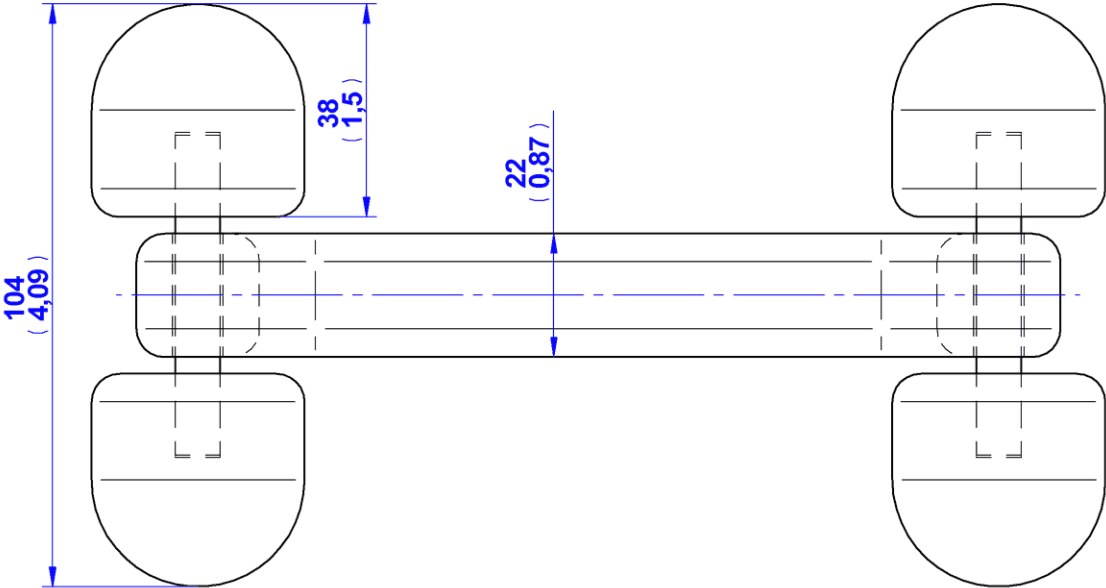
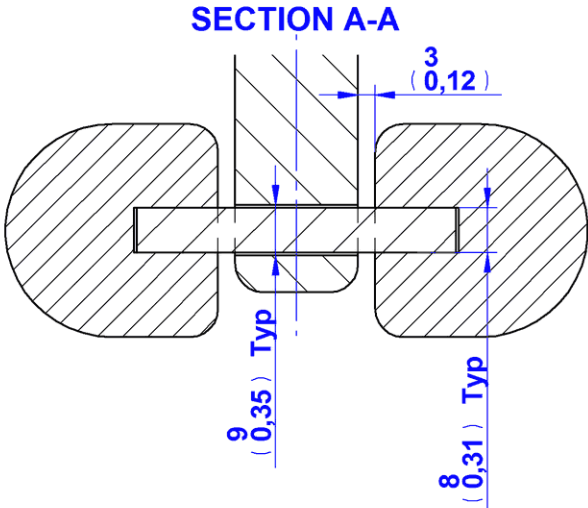
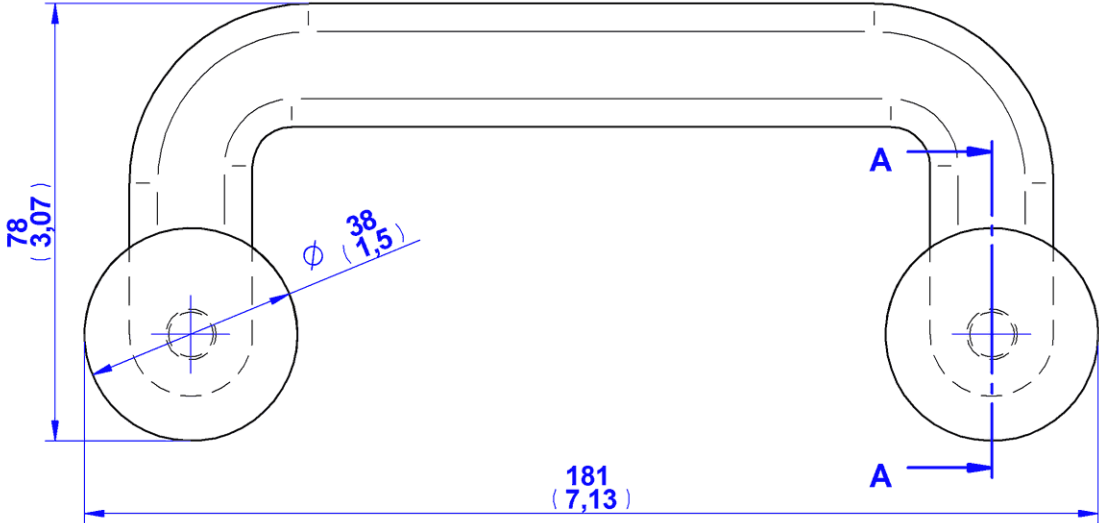

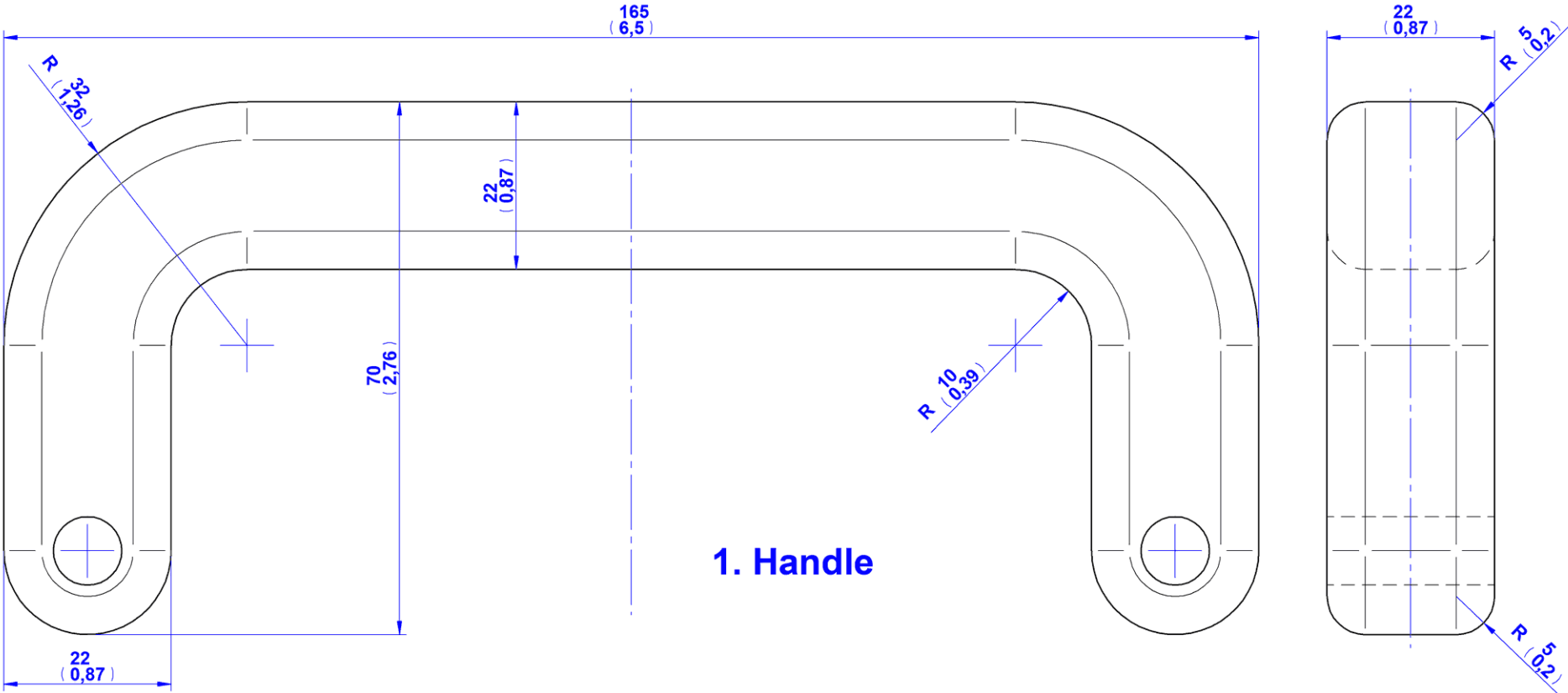

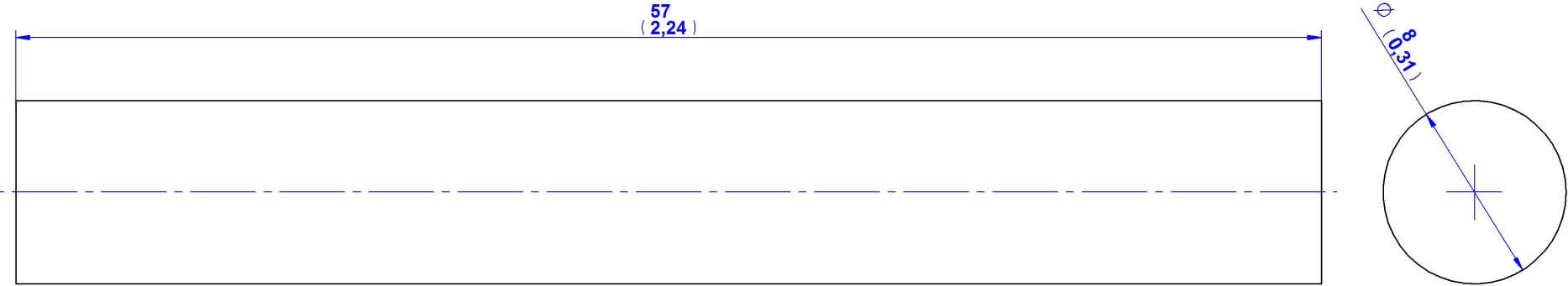

**2. Axle**

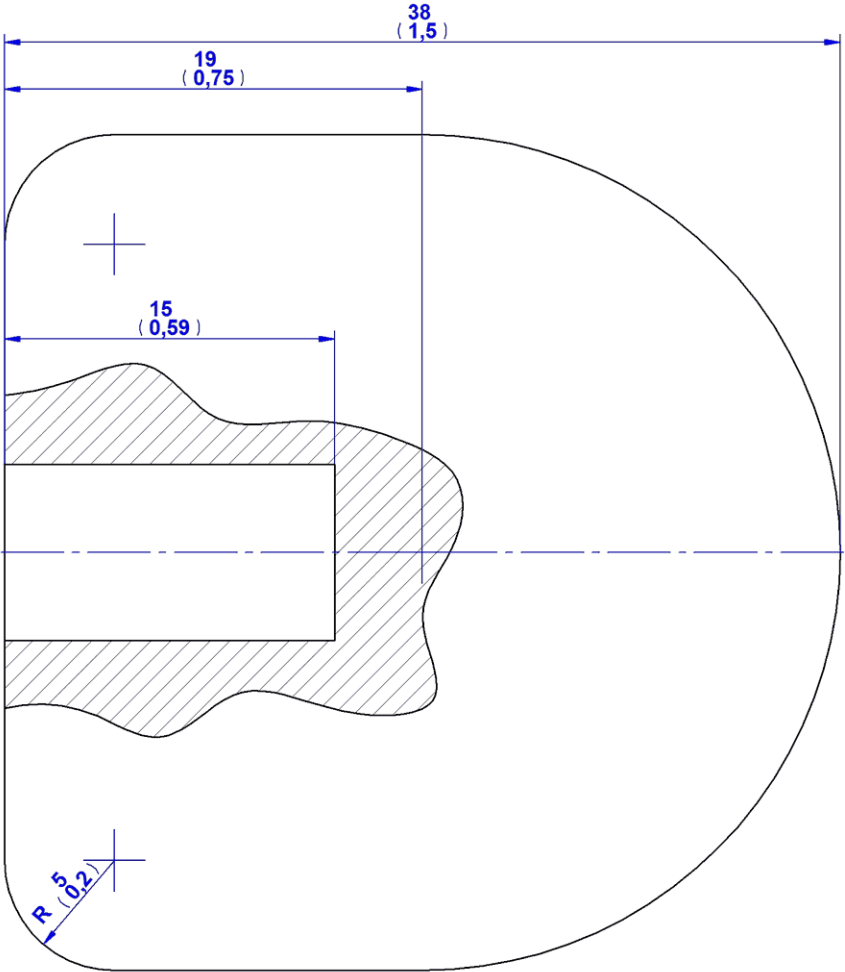

### 3. Roller

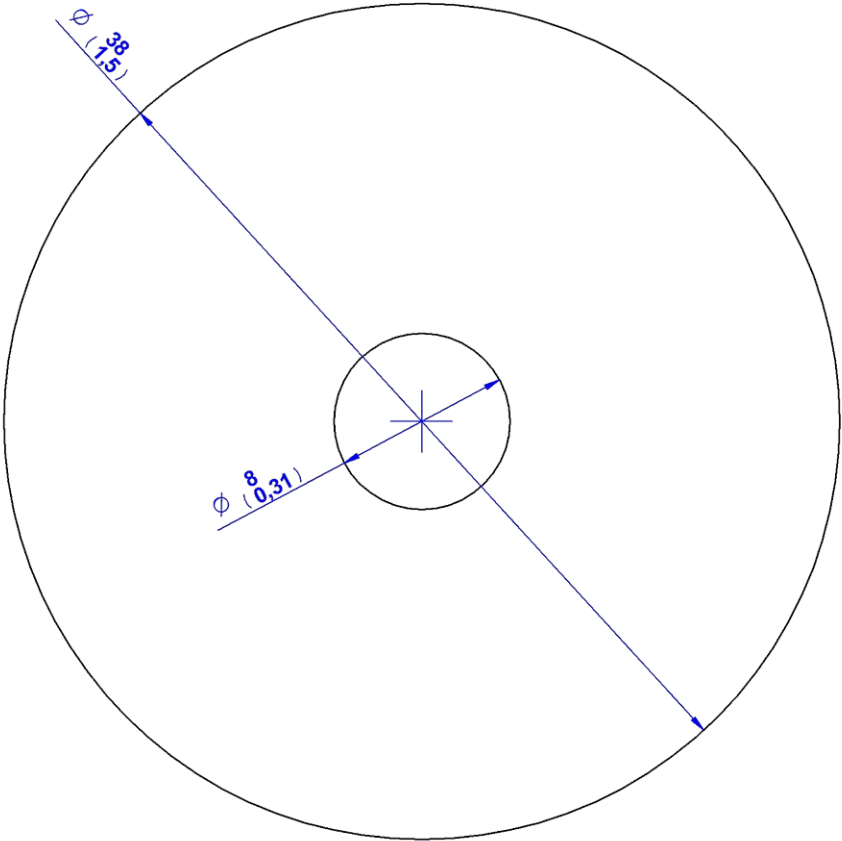

## Assemblage instructions

Pull the Axles (Parts 2) through the holes D9mm on the Handle (Part 1) and attach the Rollers (Parts 3) to all the ends of Axles (Parts 2) with glue.

