

Wooden handle massager with balls - Free woodworking plan

This home wooden handle massager with balls is designed by the ancient principle of reflexology to stimulate nerve endings.

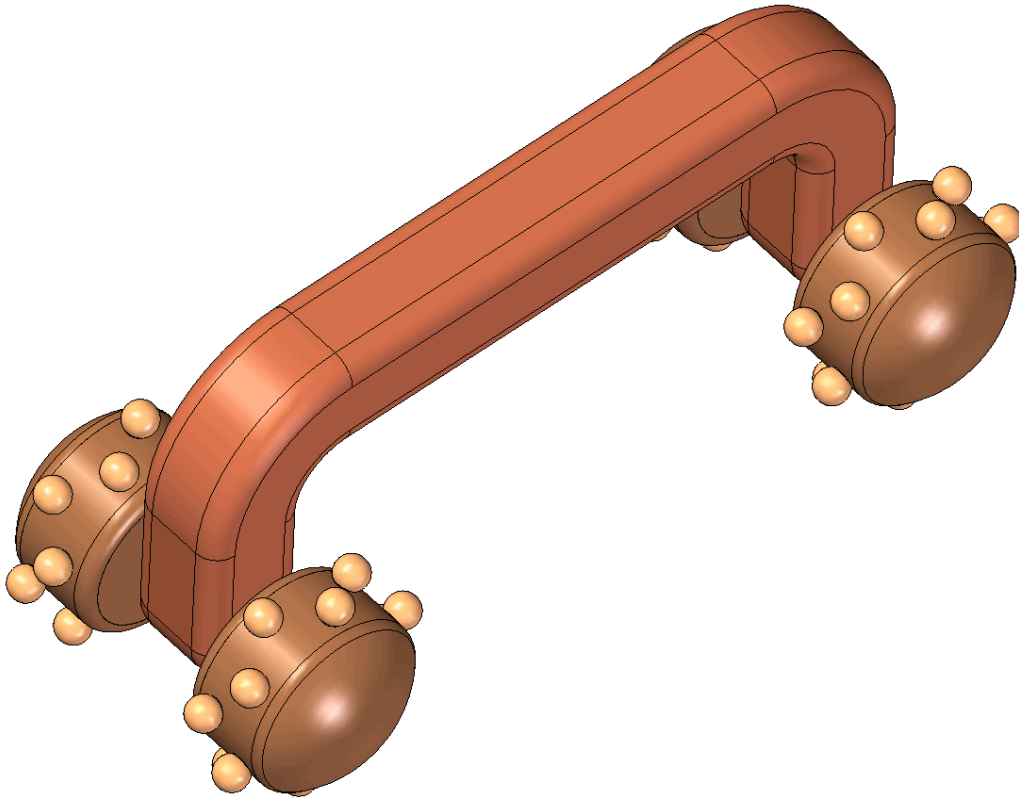

Wooden back massager with balls - Parts list

Item Number	Title	Material	Quantity
1	Handle	Wood	1
2	Axle	Wood	2
3	Roller	Wood	4
4	Massage ball	Wood	48

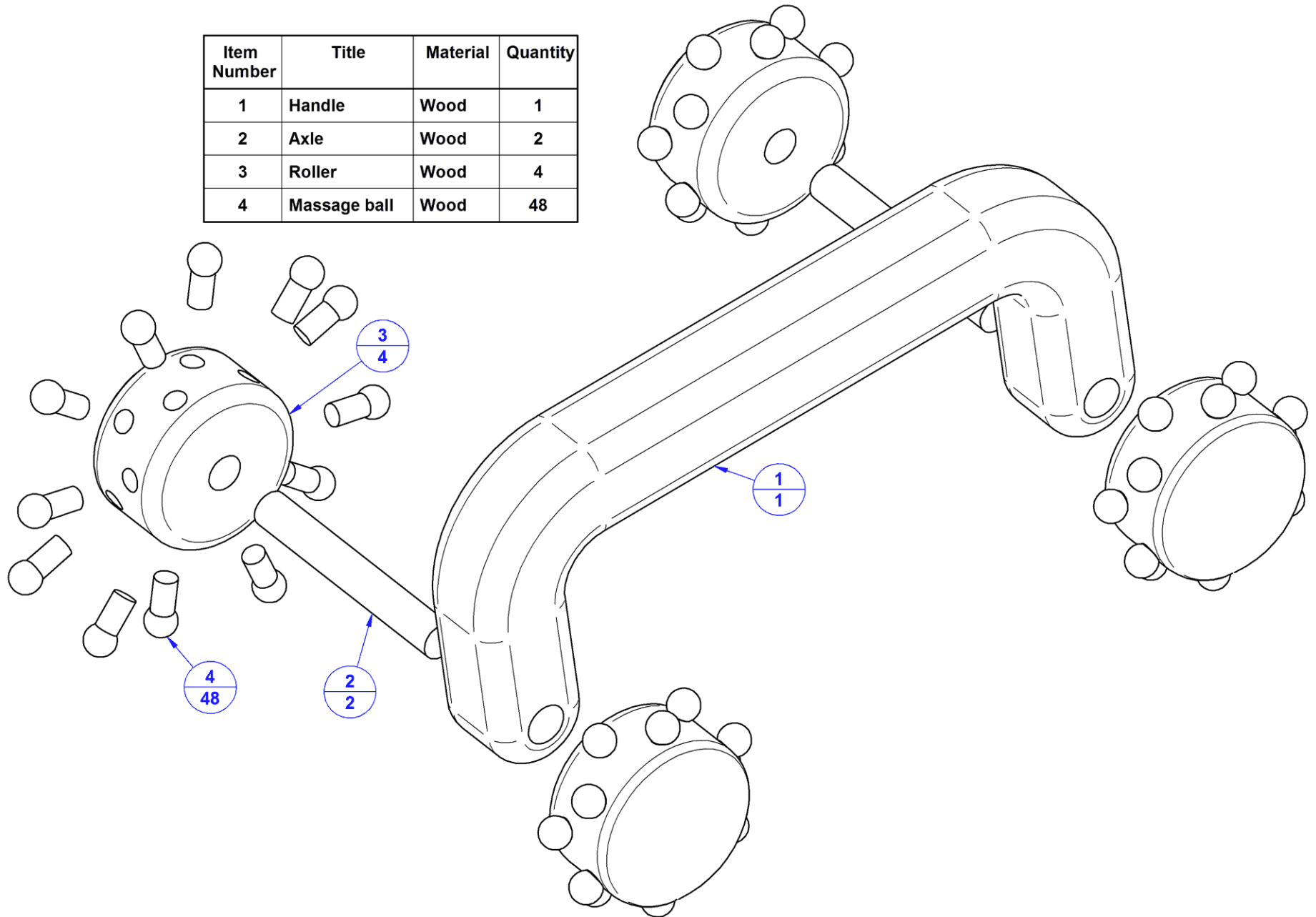

Wooden back massager with balls - Assembly 2D drawing

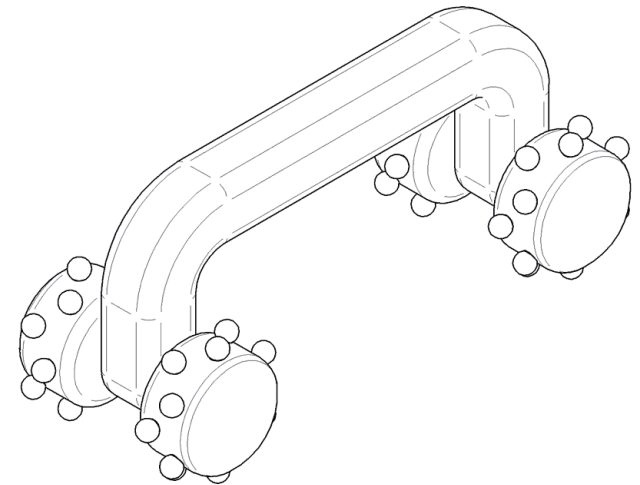
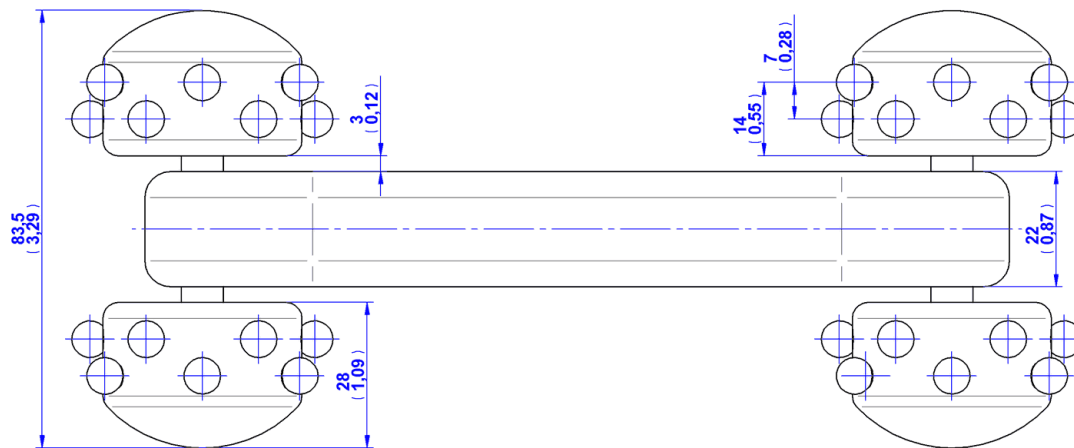
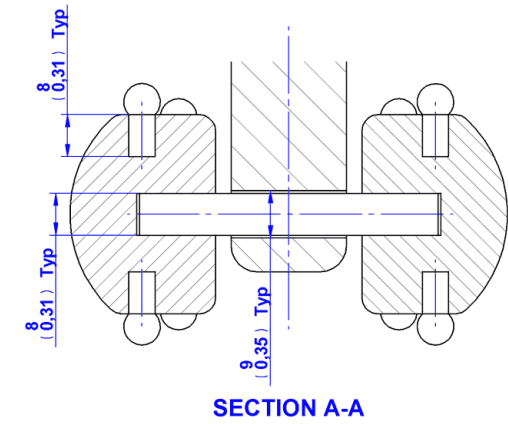
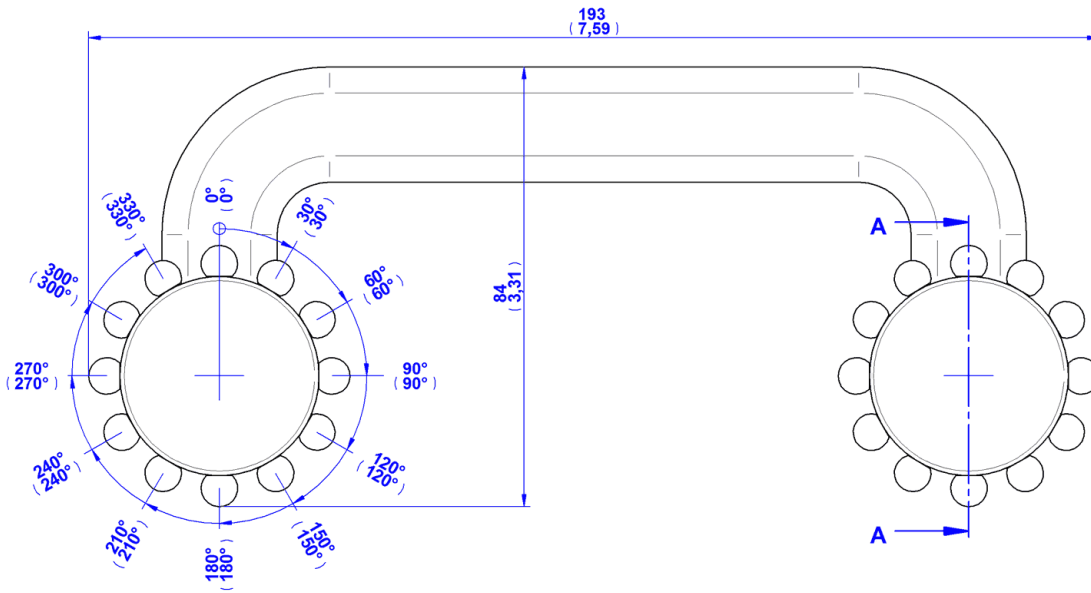

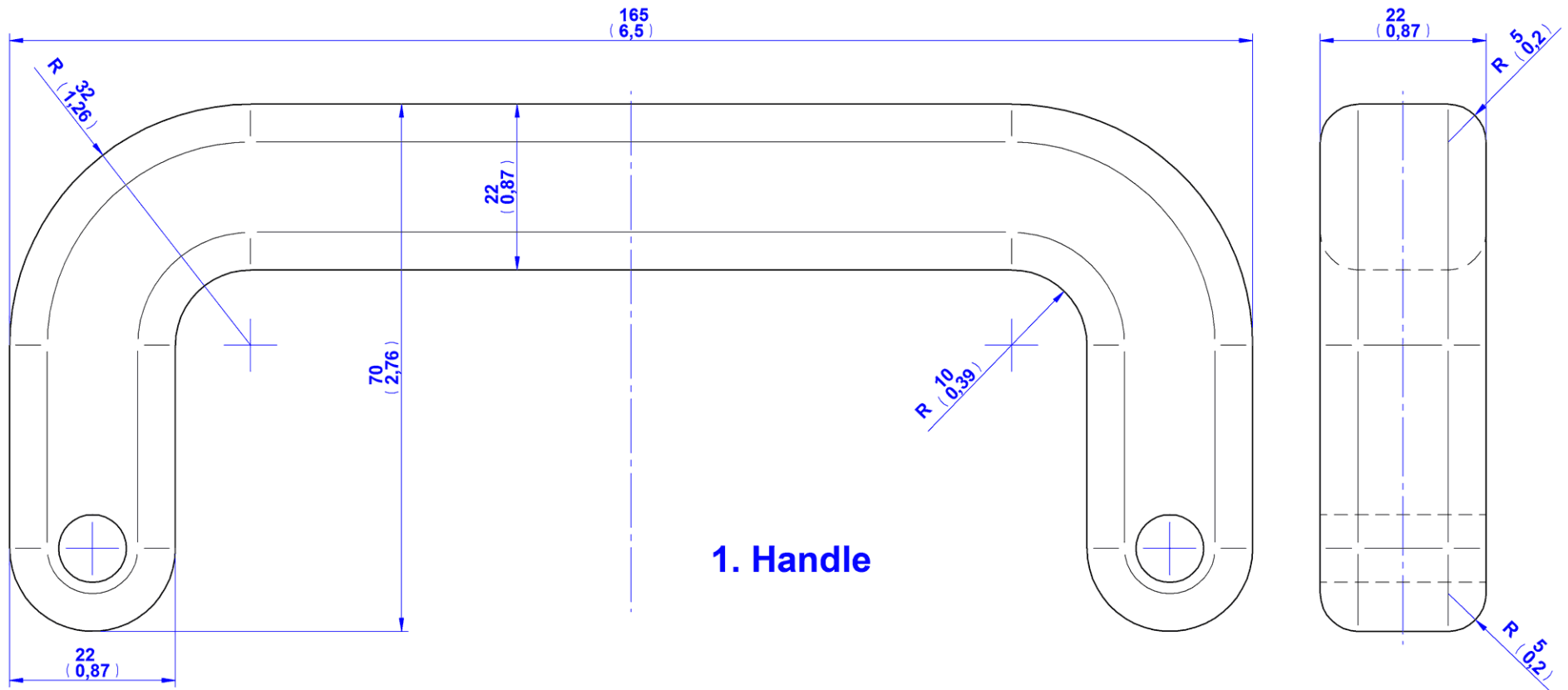

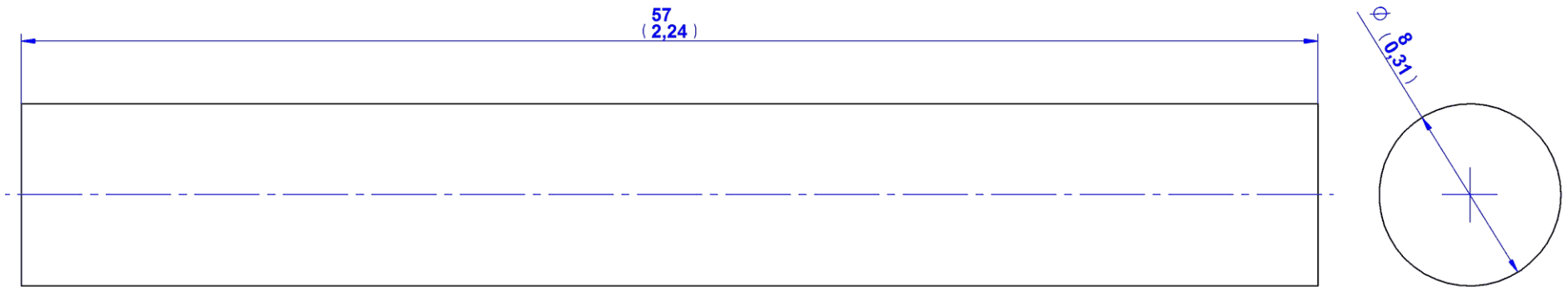

2. Axle

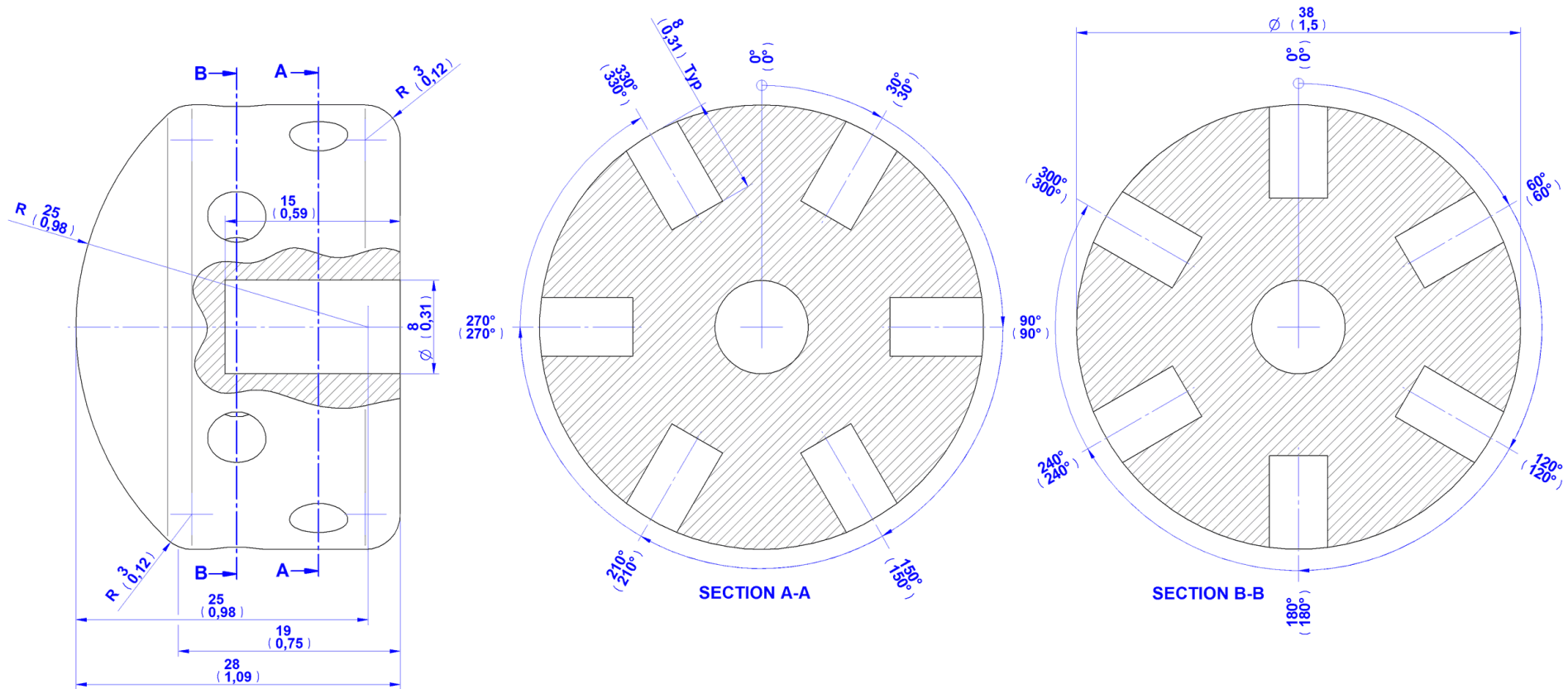

3. Roller

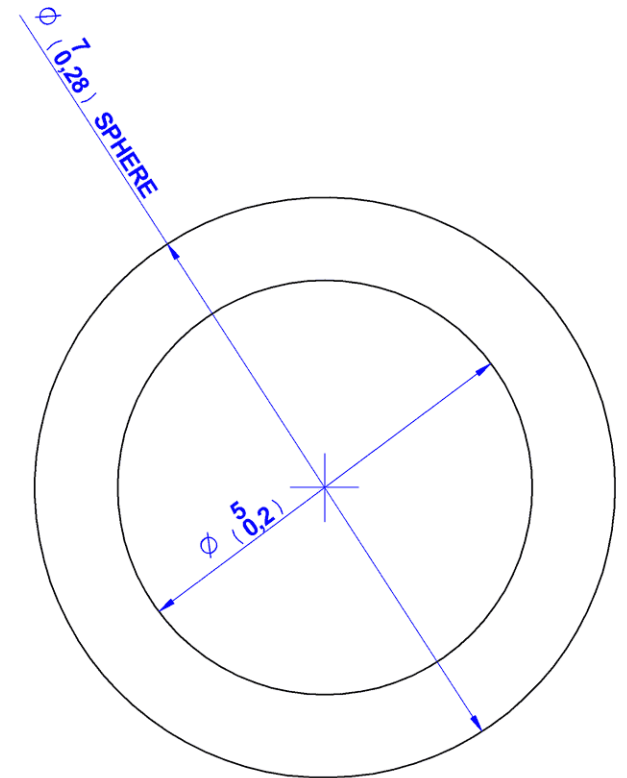
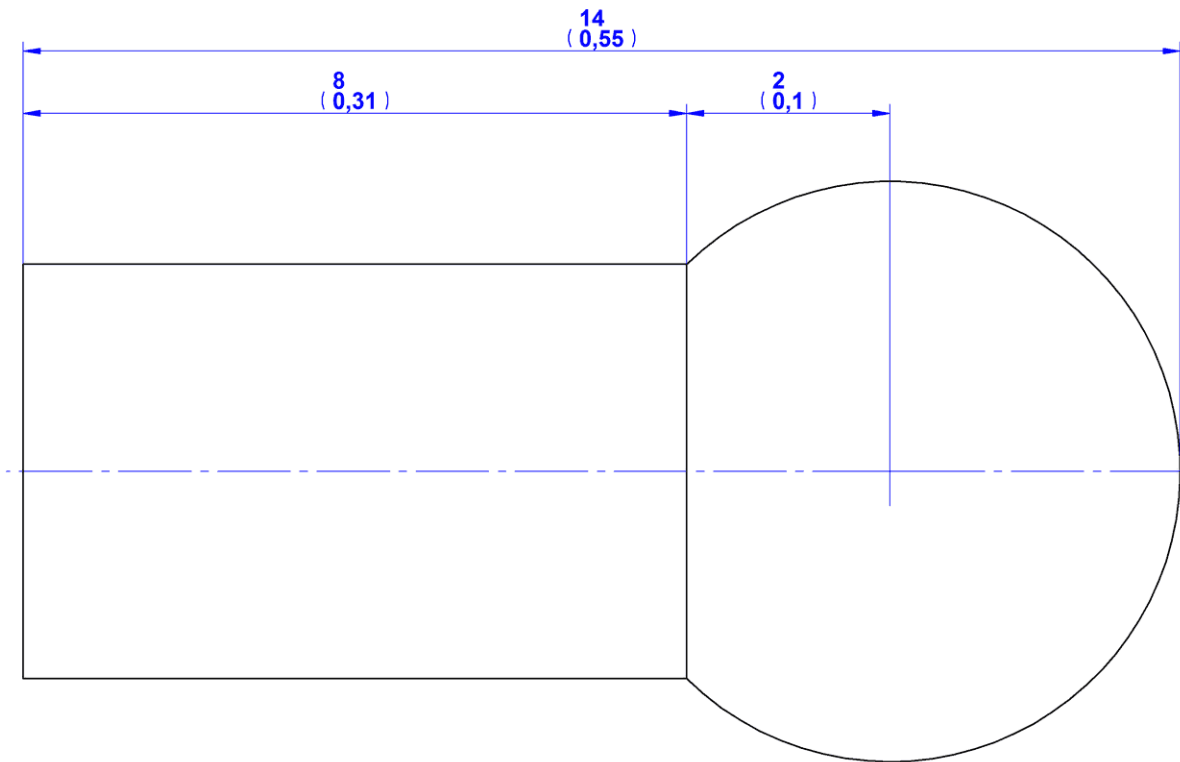

4. Massage ball

Assemblage instructions

1. Attach the Massage balls (Parts 4) with glue to the Roller (part 3).

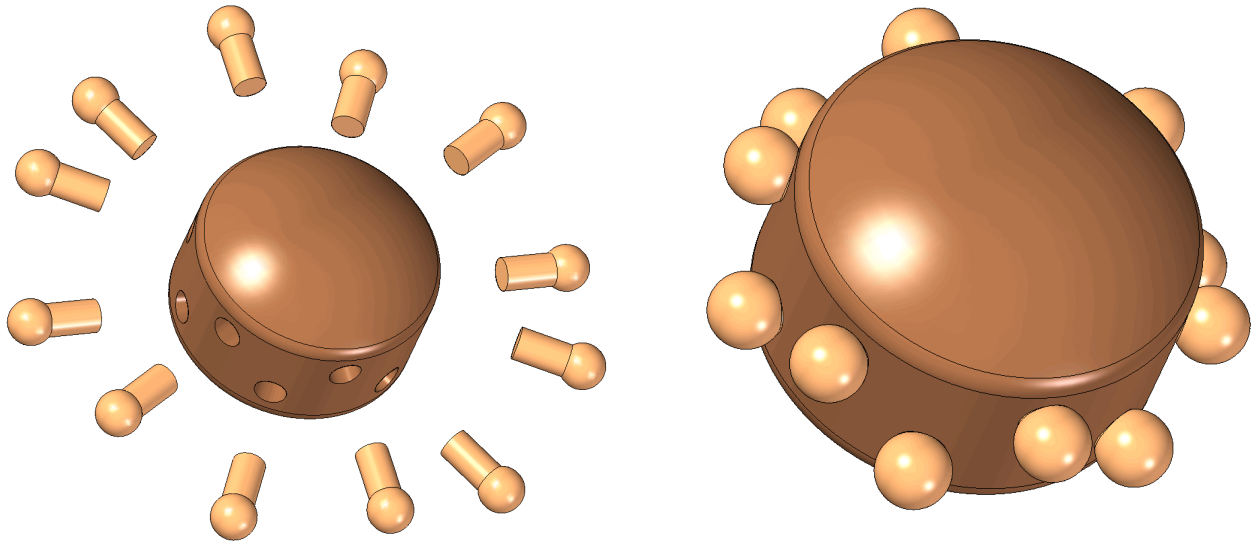

Make four of these subassemblies.

2. Pull the Axles (Parts 2) through the holes D9mm on the Handle (Part 1) and attach the subassemblies made in the previous step to all the ends of Axles (Parts 2) with glue.

